

ROOF WITH THERMAL INSULATION – GRASSING, REVERSE ORDER OF LAYERS, PLASTIC FOIL

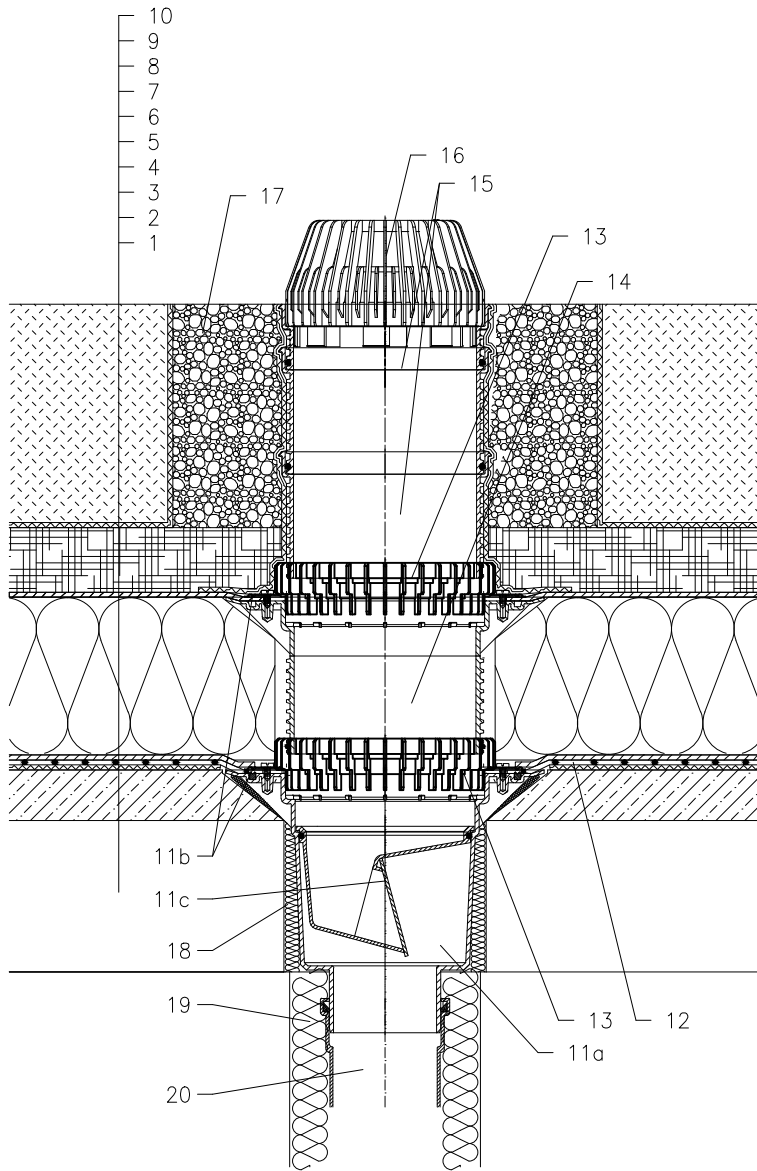

- 1 SUPPORT CONSTRUCTION
- 2 CONCRETE GRAVITY LAYER
- 3 SEPARATING AND DILATATION LAYER
- 4 PLASTIC FOIL WATERPROOFING
- 5 SEPARATING AND DRAINAGE LAYER
- 6 XPS THERMAL INSULATION
- 7 DRAINAGE LAYER
- 8 WATER ACCUMULATING LAYER
- 9 FILTER LAYER
- 10 VEGETATION LAYER (OVER 200mm)
- 11a DRAIN BODY HL616K WITH FLANGE
- 11b SEALING KIT HL86.0 – WITHOUT SHEETING,
- 11c FROST-PROOF FLAP HLO606.3E
- 12 PRE-CUT PART FOR SEALING COLLAR, SEE TOPIC "ATTACHEMENTS"
- 13 DRAINAGE RING HL190
- 14 EXTENSION HL618 WITH FLANGE INCL. O-RING
- 15 EXTENSION HL620
- 16 LEAF STRAINER HL195
- 17 GRANULAR FILL
- 18 ASSEMBLY FOAM
- 19 DOWNPIPE THERMAL INSULATION
- 20 DOWNPIPE

NOTICE:

TO HEAT THE DRAIN, YOU MAY USE HEATING KIT HL609 WITH SELF-REGULATING HEAT SOURCE 36W/230V. (THE HEATING TAPE MUST BE WRAPPED AROUND THE DRAIN BODY BEFORE INSTALLATION).
 RECOMMENDED BOREHOLE DIAMETER IS $\varnothing 290\text{mm}$, OR $\varnothing 290 \times 290\text{mm}$
 DURING INSTALLATION TAKE CARE, THAT THE FLANGE POSITION IS ON THE LOWEST LEVEL OF DRAINAGE. WE RECOMMEND, TO SITE IT APPR. 1cm BELOW THE SCREED.
 TO AVOID CONDENSATE WATER TAKE CARE OF THERMAL INSULATION ON THE CONSTRUCTION SITE.

132322AY