

NON-INSULATED – WALKABLE, PAVEMENT ON STANDS, PLASTIC FOIL WATERPROOFING

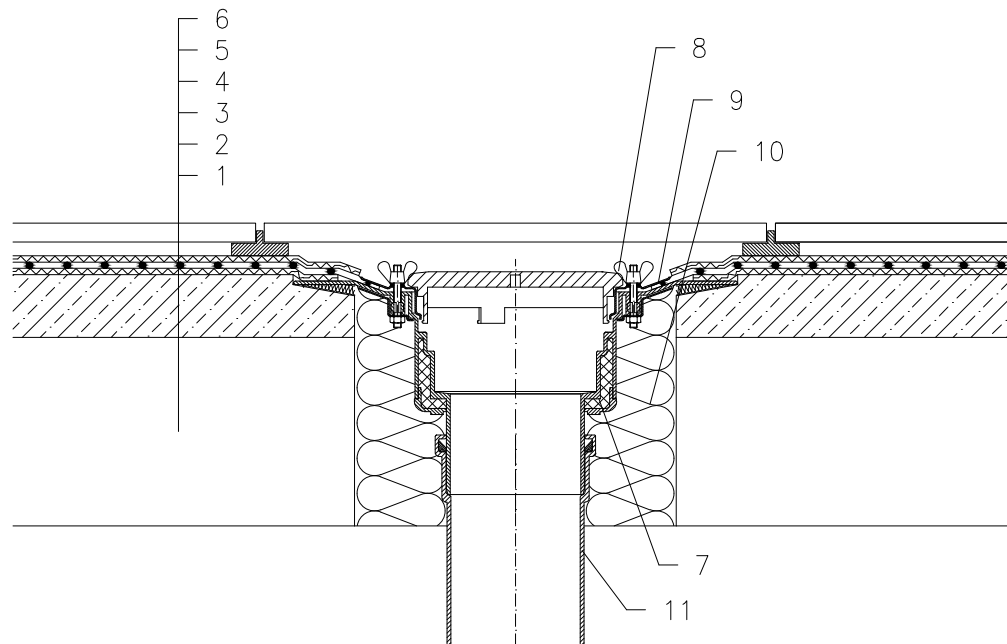

- 1 SUPPORT CONSTRUCTION
- 2 GRAVITY LAYER
- 3 DILATATION LAYER
- 4 PLASTIC FOIL WATERPROOFING LAID LOOSE
- 5 DILATATION LAYER
- 6 PAVEMENT ON STANDS
- 7 FLAT-ROOF DRAIN HL62 WITH INSULATED DRAIN BODY, FLANGE AND STAINLESS STEEL CLAMPING RING, (FOR PVC SHEETINGS FLAT-ROOF DRAIN HL62P; FOR FPO SHEETINGS BASED ON PP FLAT-ROOF DRAIN HL62F)
- 8 FLAT GRATE HL170
- 9 SEALING PACKING, (SEE ACCESSORIES)
- 10 ASSEMBLY FOAM
- 11 DOWNPIPE

NOTE:

FLAT-ROOF DRAIN HL62.1, (FOR PVC SHEETINGS FLAT-ROOF DRAIN HL62.1P; FOR FPO SHEETINGS BASED ON PP FLAT-ROOF DRAIN HL62.1F) HEATED (230V, 10-30 WATTS) CAN BE USED.  
 ASSEMBLY INLET:  $\varnothing$ 255 MM, ALTERNATIVELY 255X380 MM

112132